

Spectrum and Radio Resource Management in Cognitive Heterogeneous Wireless Networks

O. Sallent, L. Giupponi, J. Nasreddine, R. Agustí, J. Pérez-Romero
Universitat Politècnica de Catalunya (UPC)

ABSTRACT- This paper presents a framework to achieve an optimized dynamic spectrum and radio resource usage in heterogeneous wireless network and multi-operator scenarios. The envisaged technical solution follows a layered approach, where Joint Radio Resource Management (JRRM) and Advanced Spectrum Management (ASM) mechanisms are identified at both intra and inter-operator levels. The interaction between layers, together with reference operative time scales, is described and accompanied by an illustrative story case. Moreover, the importance of cognitive network functionalities is highlighted as a key enabler. Finally, the different steps of the cognition cycle are further developed, with particular emphasis on guiding principles to be applied to the different stages.

INTRODUCTION

Wireless technologies are rapidly evolving in order to allow operators to deliver more advanced multimedia services. HSPA (High Speed Packet Access) for uplink and downlink is seen as intermediate evolutionary step since the first wave of WCDMA-based (Wideband Code Division Multiple Access) networks rollout while E-UTRAN (Evolved UMTS Terrestrial Radio Access Network) is the long term perspective for the 3GPP technology family. Similar paths are drawn from the 3GPP2 around the evolution of CDMA2000. Moreover, the IEEE 802 is producing an evolving family of standards, such as 802.11 local, 802.15 personal, 802.16 and 802.20 metropolitan and 802.22 regional area networks.

Furthermore, the regulatory perspective on how the spectrum should be allocated and utilized in a complex and composite technology scenario is evolving as well. The evolution is towards a cautious introduction of more flexibility in spectrum management together with economic considerations on spectrum trading. This new spectrum management paradigm is driven by the growing competition for spectrum and the requirement that the spectrum is used more efficiently [1]. Then, instead of the classical fixed spectrum allocation to licensed systems and services, which may become too rigid and inefficient, it is being recently considered the possibility to use Flexible Spectrum Management (FSM) strategies that dynamically assign spectrum bands in accordance with the specific traffic needs in each area [2]. There are different FSM scenarios

presenting different characteristics in terms of technical, regulatory and business feasibility. While a fully enabled FSM scenario can be envisaged at a rather long-term perspective, there are already some basic FSM scenarios that are becoming a reality [3]. Spectrum refarming, providing the possibility to set-up communication on a specific RAT in different frequency bands (e.g. refarming of GSM spectrum for UMTS/HSxPA communications), is a first example. Another case for FSM arises from the so-called digital dividend, which corresponds to the frequencies in the UHF band that will be cleared by the transition of analog to digital television. The cleared spectrum could be utilized by mobile TV or cellular technologies like UMTS, LTE, WiMAX, etc. and also for sharing flexibly spectrum between smart radio technologies. The exploitation of the so-called TV White Space, which refer to portions of spectrum that are unused either because there is currently no license holder for them, or because they are deliberately left unused as guard bands between the different TV channels, is another opportunity for FSM mechanisms.

The multiplicity of Radio Access Technologies (RATs) and network operators, their different characteristics and the flexibility in spectrum management point out a challenging scenario that introduces relevant opportunities to increase efficiency. Certainly, the heterogeneous wireless network vision may be realized in a number of techno, regulatory and business scenarios, which will require diverse solutions and technologies for a proper exploitation of such opportunities. In any case, the framework envisaged above can only be fully accomplished by further enhancing the Radio Access Networks (RANs) towards Cognitive Network (CN) technologies. A CN has a cognitive process that can perceive current network conditions, and then plan, decide and act on those conditions. The network can learn from these mechanisms and use them to make future decisions [4]. Thus, CNs have the potential to utilize the large amount of unused spectrum in an intelligent way.

The ultimate objective of this paper is to present and develop a framework for technical solutions leading to an optimized utilization of the spectrum and radio resources. Clearly, the solution framework requires several strategies to be developed synergistically and, for this to succeed, the support of CN features is a must.

The rest of the paper is organized as follows. First, the technical challenges raising in future wireless scenarios are presented together with the envisaged technical solution, which is based on a four-layer architecture involving radio and spectrum management strategies at both intra- and inter-operator levels. A story case is presented, illustrating the inter-layer operation. Second, the envisaged layered strategy is integrated into the cognitive cycle and some hints into the applicable mechanisms and solutions for the different steps are provided. Particular emphasis is placed on the decision making processes, which are further developed for the different layers. Finally, the paper concludes with a summary of the main concepts discussed.

ENVISAGED TECHNICAL SOLUTION

A. Scenario considerations

Mobile cellular services in a given geographical area are usually provided by several competing operators. Operators usually deploy more than one RAT in the same coverage and try to differentiate themselves not only by the technology itself, but also by using different business models.

For a given operator, the network deployment is usually designed to support the expected traffic level at the busy hour. Certainly, the inherent dynamic nature of the mobile cellular scenario makes the offered traffic profiles impossible to be accurately predicted along time and space. Current offered traffic may differ from the planned level because of e.g. (1) fluctuations due to statistical call/session generation processes in the short term (i.e. below a few minutes time scale), and/or (2) variations in the long term (e.g. within the whole busy hour period) of the current average offered load value with respect to the planned one for a variety of reasons, e.g. faster service penetration than predicted, actual spatial traffic distribution different from the one considered in the planning exercise, etc. In either case, the operator faces mismatches between the required capacity and the available capacity. In case of spare available capacity, this could lead to unnecessary waste of scarce radio resources which could perhaps be used by other operators/RATs. On the contrary, in case of lack of available capacity, non-desirable QoS level is provided to customers. In this case, RAN extension can be a good solution for long term deviations, although it may require weeks/months until new infrastructure is added. Consequently, new potential solutions providing adaptability in diverse time scales could be considered in order to face the above traffic variations.

In that respect, a number of base-line techniques have been identified, proposed and analyzed in recent years to cope with heterogeneous wireless networks with flexible spectrum management capabilities [5]:

- ⇒ Joint Radio Resource Management (JRRM): Process that enables the management (assignment, de-assignment) of users to different radio access systems for a fixed spectrum band allocated to each of these systems. Vertical handover (i.e. handover between different systems) constitutes the key procedure in support of JRRM.
- ⇒ Advanced Spectrum Management (ASM): Process that enables the dynamic management (assignment, de-

assignment, sharing) of spectrum blocks within a single or between different radio access systems.

These base-line strategies target to facilitate the most efficient radio resource utilization possible, while providing a “seamless experience” to the mobile users. The different resource optimization techniques have to be integrated into a coherent framework, given that each use case poses special problems of resource utilization and requires a different approach to achieve the optimal resource allocation. In this respect, [6] discusses the fundamental aspects and proposes a corresponding architecture explaining the basic functional modules through a set of use-cases.

B. Proposed solution: a layered approach

The proposed solution illustrated in Figure 1, intends coping with actual traffic conditions through the most suitable mechanism from a multi-layer structure. The ultimate objective of the layered approach would be to achieve an automatic, self-adaptive operation, where suitable mechanisms are activated at suitable time. To this end, four different layers are identified:

- a) Intra-operator JRRM: At this layer, current traffic demand is managed by means of algorithms applied over the pool of resources belonging to a given operator. These algorithms flexibly assign users to different RATs of the same operator. In that respect, this layer operates over a fixed spectrum band assigned to each of these RATs.
- b) Inter-operator JRRM: At this layer, current traffic demand is managed through an alternative operator providing access to the required services in the scenario at a certain time by assigning users flexibly to different RATs of a different operator. A trading agent implemented as a “meta-operator” may be the actor that provides the bridge among different operators.
- c) Intra-operator ASM: At this layer, current traffic demand is managed by means of dynamic spectrum management algorithms, which come up with suitable spectrum re-assignment to cells and RATs within a given operator. Intra-operator ASM re-arranges the spectrum bands allocated to that particular operator, enabling the dynamic management of spectrum blocks within a single or between different RATs. Consequently, it determines the capacity for each different RATs of the operator.
- d) Inter-operator ASM: At this layer, current traffic demand is managed with the help of additional resources that the operator rents to/buys from other operators. Inter-operator ASM considers the granularity of the associated spectrum to each RAT and thus it is generally applied to substantial pieces of radio spectrum (e.g. renting 5 MHz band to deploy an additional UMTS carrier).

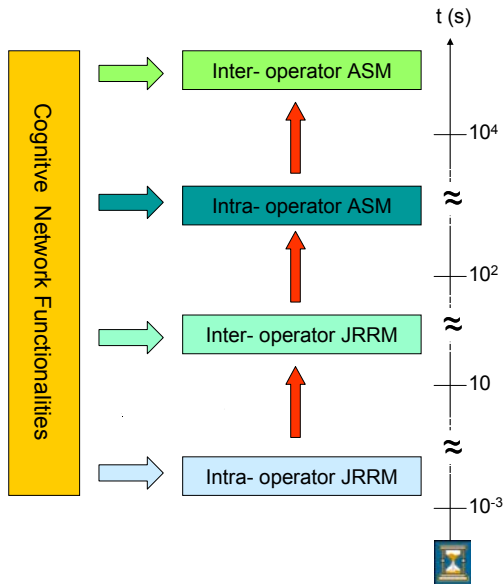

Figure 1 Layered intra/inter-operator and JRRM/ASM approach

C. Inter-layer operation

The four strategies identified above are also distinguished by the time scales at which they are applied as illustrated with some reference values in Figure 1. In particular, JRRM strategies operate at the shortest time scale (in the order of minutes and below) whereas ASM strategies operate at a longer time scale (at least in the order of minutes).

The main objective of the integrated layered approach is to achieve a synergistic operation of the different mechanisms, leading to an overall optimized exploitation of the available resources. To this end, triggering events activating the suitable layer at the suitable time are needed to adapt to the time and space-variant traffic demand.

The envisaged normal flow from the perspective of a reference operator with a certain deployment of heterogeneous RANs in a given scenario is described in the following:

1) By default, the reference operator will attempt to provide the service to its customers through its own deployed infrastructure, thus intra-operator JRRM is applied upon every service set-up request. Intra-operator JRRM mechanisms should provide seamless service across the different RANs and cell sites. For a reference operator OP#1, intra-operator JRRM solutions are applied for a given spectrum $B_{OP\#1}$ allocated to OP#1 and a given spectrum split between the different RATs deployed by OP#1 (i.e. $B_{RAN\#1}$ and $B_{RAN\#2}$), as illustrated in Figure 2.

2) In case of short-term difficulties in providing accessibility to OP#1's network (i.e. a service request should be blocked or provided with insufficient QoS), inter-operator JRRM mechanisms may be activated in order to maintain high QoS perception for the user. In this case, the service can be set-up with satisfactory QoS through another operator with whom agreements have been established. Taking into account that inter-operator JRRM mechanisms imply some kind of revenue sharing model between the involved operators, the

reference operator may establish triggering actions tending to skip inter-operator JRRM and move to intra-operator ASM at an early stage.

3) Assuming that good JRRM algorithms are implemented, if key performance indicators (KPIs) at a medium to long-time scale point out degradation in QoS levels, this may indicate that JRRM mechanisms have reached their limits with the current assignment of spectrum in the scenario and the current traffic conditions. In such case, the operator may question whether the spectrum mapping to cells/RATs is suitable in the actual radio network state. This will be targeted by intra-operator ASM mechanisms, which will look for a suitable spectrum/RAT assignment fitting the current conditions, eventually implemented by dynamic network planning. The outcome of the intra-operator ASM algorithm is a more suitable system operation point. That is, intra-operator ASM solutions are applied for a given spectrum $B_{OP\#1}$ allocated to OP#1 as illustrated in Figure 2. It is worth noting that, in case that for instance RAN #2 supports all services provided by RAN#1 with higher spectral efficiency, then the ideal outcome of intra-operator ASM would be $B_{RAN\#2} = B_{OP\#1}$. However, if RAN #1 is a legacy technology, the operator may be interested in further exploiting its investment in RAN#1 and to continue providing service to legacy terminals, etc. and, therefore, not all the allocated spectrum to OP#1 could be assigned to a single RAN.

4) In case the synergized operation between JRRM and intra-operator ASM reaches its limits, which again could be observed by QoS degradation, it can be concluded that the amount of available resources for the operator is not enough to cope with the offered traffic. In such case, inter-operator ASM mechanisms are envisaged as a source of getting additional spectrum.

Figure 3 illustrates how inter-operator ASM mechanisms manage different amounts of spectrum to different operators; i.e. $B_{OP\#1}$ and $B_{OP\#2}$.

The above strategies need to be fed and supported by mechanisms that allow extracting the network status and operation point, prior to defining the best possible actuation on the network. This is facilitated by the CN element in Figure 1 that monitors and captures the network status at different levels, which are of interest for the different layers.

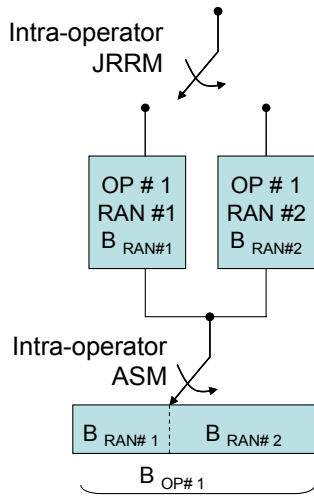

Figure 2 Illustration of intra-operator mechanisms: JRRM and ASM

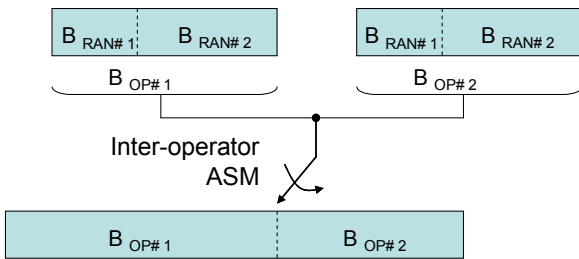

Figure 3 Illustration of inter-operator ASM mechanism.

D. Story case

Peter is a business customer with a high QoS profile. Peter owns a multi-RAT terminal. Peter is on the way to the train station and makes a call. Initially, intra-operator JRRM assigns the connection to the 3G-RAT in OP#1 and performs several horizontal handovers as Peter is moving across the area. Reaching an area where 3G coverage is poor, intra-operator JRRM decides a vertical handover to the 2G-RAT in the same operator.

Once at the train station, serious delays in train schedules occur. Consequently, the station is more crowded than usual. Peter wishes to call home to say that he will be late. His own operator's network is seriously blocked, since difficulties in finding new cell sites in the area have prevented the operator to extent its network deployment in the last months and, therefore, the deployed capacity cannot cope with such a worst-case traffic demand. Nevertheless, Peter is able to make the call through another operator's network, thanks to inter-operator JRRM agreements. Even though the revenue for the service goes to the serving operator, Peter's operator has been able to meet the agreed QoS in terms of accessibility. The overall inter-operator process has been transparent to Peter.

Given that a high number of users are being re-directed to other operators through inter-operator JRRM, intra-operator ASM is activated in order to find a spectrum assignment that fits better with the actual space/time traffic distribution. Additional 2G-RAT carriers are assigned in the area, so that further Peter's calls are supported again through intra-operator JRRM mechanisms over the upgraded pool of radio

resources assigned to 2G-RAT. The dynamic planning associated with intra-operator ASM has significantly reduced the number of inter-operator exchanges in the train station area. However, the QoS provided in a nearby area with the new planning is not fully satisfactory. Even though the network performance from an overall perspective (i.e. averaged over the train station and nearby area) has improved and, therefore, intra-operator ASM has revealed to be effective in this case, the operator targets better overall performance. Consequently, inter-operator ASM mechanism is triggered at a later stage in order to get additional spectrum from other operators. Assignment of additional spectrum to current cell sites would be a feasible solution meanwhile new cell sites can be deployed.

EXPLOITING COGNITIVE NETWORK MECHANISMS

Mobile communication networks are dynamic in nature. Dynamism arises from multiple dimensions: propagation conditions, traffic generation processes, interference conditions, mobility of radio transceivers, etc. Thus, changing network and scenario conditions may degrade network performance and QoS. Consequently, modern networks must provide mechanisms to adapt to changes by introducing cognitive network features. Cognitive network refers to a network being able to sense the radio environment (sensing the radio context, service context, location context and user context), automatic reasoning (interpreting the radio environment), self-actuating (reacting to the changes), self-tuning (tuning the radio and implementation parameters) and self-healing (fault management). A cognitive network exploits the cognitive cycle [7][8], as illustrated in Figure 4.

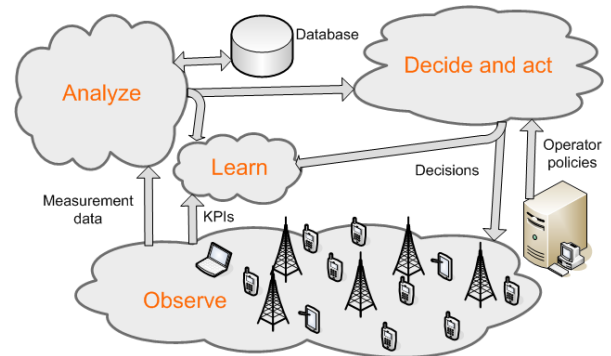

Figure 4 Integration of spectrum and radio resource management strategies in the cognitive cycle

The proposed layered approach, considering JRRM/ASM mechanisms at both inter/intra operator level, should be integrated in the cognitive cycle in order to target the highest possible efficiency and advanced realization. To this end, the following subsections provide some hints into applicable mechanisms and solutions.

A. Observe

The observation of the network status involves a large number of measurements and metrics. Measurements and metrics can be obtained at different network elements (e.g. mobile terminals, base stations). Measurements relevant for a particular function of the cognitive cycle need to reach the

network element(s) where the corresponding function is implemented. Typically, in 2G/3G cellular networks, this is associated with a central node. Nevertheless, there is a clear trend in future wireless network towards decentralization of the intelligence and decision making processes, even residing some cognitive cycle functionalities at the mobile terminal (e.g. as envisaged in IEEE P1900.4 [9]). Measurements and metrics of interest may be at connection level (e.g. path loss from terminal to cell site, average bit rate achieved over a certain period of time, etc.) or at system level (e.g. cell load, average cell throughput achieved over a certain period of time, etc.).

B. Analyze

This stage considers relevant inputs obtained from the observation phase and its objective is the identification of relevant changes in the network status affecting the provisioned QoS levels. Furthermore, the analysis may consider the dynamics on inter-cell interactions (i.e. mutual interference from any pair of cells) as a key indicator reflecting the radio interface conditions and its evolution due to changes in requested services, spatial distribution of users, etc. For example, inter-cell interactions can be represented in smart forms, such as the so-called *coupling matrix* [10]. For the particular case of a WCDMA system, the coupling matrix is defined as the Jacobian matrix of the interference system of equations in uplink and, correspondingly, the Jacobian matrix of the total transmitted power system of equations in downlink. In order to illustrate that the coupling matrix has interesting mathematical properties that can be used as performance indicators, Figure 5 shows a high correlation between the spectral radius (i.e. the eigenvalue with the highest modulus) of the coupling matrix and the outage probability (i.e. the probability that a given user is not reaching the target QoS).

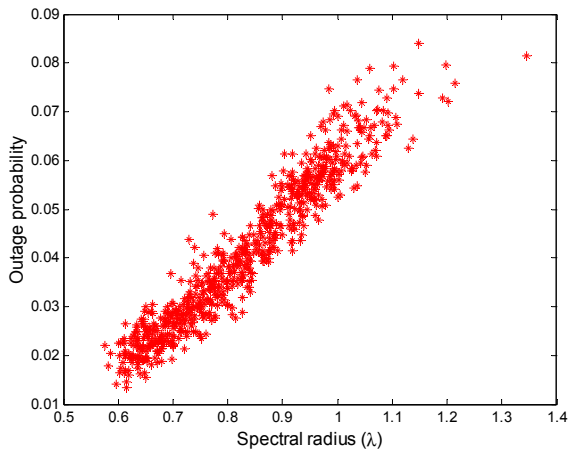

Figure 5 The outage probability as a function of the spectral radius for different mobile positions and cell loads

C. Learn

Many strategies can be envisaged as learning procedures with the ultimate goal of acquiring knowledge. In the context of cognitive networks, machine learning has been widely considered as a particularly suited framework, with multiple possible approaches [11]. Among them, reinforcement-based learning can fit into the specificities of many spectrum and radio resource management scenarios. Actually, reinforcement learning is the problem faced by an agent that

has to learn a behavior through trial-and-error interactions with a dynamic environment. On each step of interaction, the agent receives as input some indications of the current state of the surrounding environment, and according to them it then chooses an action to generate as output. This action changes the state of the environment, and the value of this state transition is communicated to the agent through a scalar referred to as reinforcement signal. The main focus relies usually on algorithms that follow or estimate a relevant gradient. The gradient seems to provide a powerful and general heuristic basis for generating algorithms that are effective and often simple to implement.

In particular, reinforcement learning mechanisms have been introduced as part of intra-operator JRRM methodologies, with the objective of allowing and maintaining a guaranteed QoS under dynamic conditions in the heterogeneous wireless access network scenarios. More specifically, [12] defines the user dissatisfaction probability as an indicator of undesired QoS level accounting for the fraction of users not reaching the desired bit rate requirements. The reinforcement learning mechanism takes the current measured dissatisfaction probability as reinforcement signal. Deviations between the actual value of the reinforcement signal and the target dissatisfaction probability are used to tune the membership functions of a connectionist Fuzzy-Neural based network implementing the intra-operator JRRM solution [12]. In this respect, as an illustrative example, Figure 6 shows the percentage of non-satisfied users in a heterogeneous scenario where UMTS, GERAN and WLAN RANs coexist along time. It can be observed that, even though at a given time a sudden increase in the number of users in the scenario occurs (i.e. from 100 to 150 users), the reinforcement learning mechanism allows attaining the target QoS (3% and 10% dissatisfaction probability - DP - in the examples shown in Figure 6).

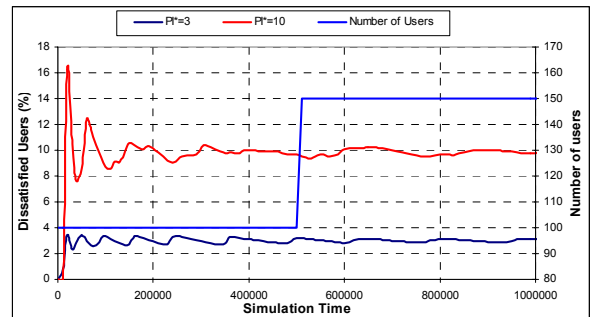

Figure 6 Illustration of the dynamic measurement of the percentage of non-satisfied users when reinforcement learning mechanisms are applied

D. Decide and act

The proposed layered approach includes four different strategies, whose objective is synergistically achieving the highest possible efficiency in spectrum and radio resource usage. Different triggers will support the inter-layer operation, then defining the most convenient strategy layer at a certain time and space. Each layer is characterized by an algorithm that implements the “decide and act” stage of the cognitive cycle. The specific algorithm applied at each level accepts many possible forms and approaches. In this respect,

the following subsections develop some considerations related to the corresponding possible solution frameworks.

Intra-operator JRRM

As discussed before, the additional dimensions introduced by the multiplicity of available RATs provide further flexibility in radio resource management and, consequently, overall improvements may follow with the use of intra-operator JRRM strategies. In this context, a key JRRM functionality is the RAT selection, which is devoted to decide the RAT that a given service request should be assigned to. This applies at session initiation (i.e. the initial RAT selection procedure) as well as along an on-going session (in this case, the RAT selection procedure may lead to a vertical or inter-system handover, changing the access network the mobile is currently connected to).

Selecting the proper RAT is a complex problem due to the number of involved variables; including the network accessibility, radio resource availability, RAT suitability to support the QoS for the requested service, operator preferences, user preferences, etc. Some possible guiding principles for RAT selection are:

1. Service-based RAT selection. A service-based RAT selection policy is based on a direct mapping between services and a prioritized list of preferred RATs.
2. Load-balancing RAT selection. This policy will distribute the load among all resources as evenly as possible. That is, whenever a mobile station can attach to more than one base station and/or RAT, the new call can be directed to the base station and/or RAT with the greatest number of available channels, i.e. the least loaded base station. Service balancing considerations could also be included [13].
3. Interference-based RAT selection. The wide sense of this principle intends to anticipate the effects that the allocation of a certain connection request to a certain cell and RAT will cause in terms of interference. Then, different criteria could be used for the RAT selection so that the interference tends to be minimized.

Clearly, an advanced RAT selection algorithm may integrate several of the above principles. For illustrative algorithms and strategies, the interested reader is referred to [14][15][16].

Inter-operator JRRM

Two different roles are identified in inter-operator JRRM: the *H-operator* (i.e. Home operator, the operator the user has a contract with) and the *S-operator* (i.e. Serving operator, the operator who is actually providing the service to the user). The inter-operator JRRM mechanism has to be transparent to the user and the price charged to the user should be the price p charged by the H-operator under normal operation. Then, the total revenue generated by the service is shared between the two involved operators, so that the H-operator will keep a fractional revenue $(1-\alpha)p$, while the S-operator will receive αp , where $0 \leq \alpha \leq 1$. Depending on the selected value for α , different business models can be envisaged (e.g. $\alpha=1$ where

the S-operator gets all revenue; $\alpha=\eta$ with $\eta \leq 1$ is the normalized S-operator load and thus revenue is shared depending on load conditions in the serving network, etc.).

It was shown in [17] that inter-operator JRRM agreements allow improving the revenue for the involved operators compared to the case where no inter-operator agreements are established.

Inter-operator JRRM mechanisms can be implemented either through direct agreements between any pair of operators, which is very similar to international roaming, or through a third trusty party (i.e. meta-operator [5]), which allows the pooling of different networks.

Intra-operator ASM

The objective of the intra-operator ASM methodology is to find the appropriate spectrum assignment to cells and RATs that satisfies the maximum number of users at all periods of time for the current assignment of spectrum bands. Thus, intra-operator ASM is an inherently dynamic process that should react in front of substantial variations in the scenario, particularly to space/time traffic distribution. This process can lead (1) to re-arrange the frequency assignment plan (i.e. dynamic network planning) while keeping the same total available amount of spectrum, (2) to release, globally or locally, some spectrum blocks, which could be used by other RATs or placed in market for inter-operator ASM purposes, (3) to request additional spectrum to inter-operator ASM mechanisms.

Intra-operator ASM copes with (1) cell load variations, which may be associated with an increase/decrease in the number of users or in the requested service characteristics (e.g. increase/decrease of the required bit rates) and/or (2) inter-cell interference conditions variations, which may be associated with changes in spatial user distribution. An illustrative intra-operator algorithm, applied to a single WCDMA network, is illustrated in Figure 7 in the form of a flow diagram. The algorithm is developed in order to come up with a suitable spectrum assignment in the scenario (i.e. mapping of carriers to cells) [10]. When relevant variations in the traffic distribution occur, this means that some of the cells that share the affected carriers are experiencing high interactions and should no longer use the same carrier. Thus, the detection of this event is a very important issue in the overall ASM methodology to guarantee the required QoS levels.

Significant capacity gains (in the order of 40%) have been reported in the literature when applying dynamic intra-operator ASM compared to reference frequency planning schemes [10][14].

Inter-operator ASM

Following the initial assignment of spectrum rights and obligations to users, circumstances may change causing initial license holders to wish trading their rights and obligations to others. The possibility to trade radio spectrum is argued by many actors to be a critical factor in the promotion of more efficient radio spectrum use [18]. Spectrum trading is a powerful way of allowing market forces to manage the assignment of radio spectrum rights and associated obligations and it is a significant step towards

a market-based spectrum management regime. Clearly, trading of spectrum is made much more powerful when it is combined with policies aimed at promoting liberalization in use (i.e. relaxation of the conditions attached to a spectrum license dealing principally with services and technologies). As liberalization provides greater flexibility, it means that spectrum trades are able to seize the opportunity for greater gains.

The key tools that a regulator needs to deploy in order to allow market forces to manage spectrum are auctions, trading and property rights (e.g. limits on emissions). In addition, some powers to address anticompetitive behavior may also be required. All these ingredients are the foundational aspects of inter-operator ASM, which would implement the specific spectrum transactions between involved parties.

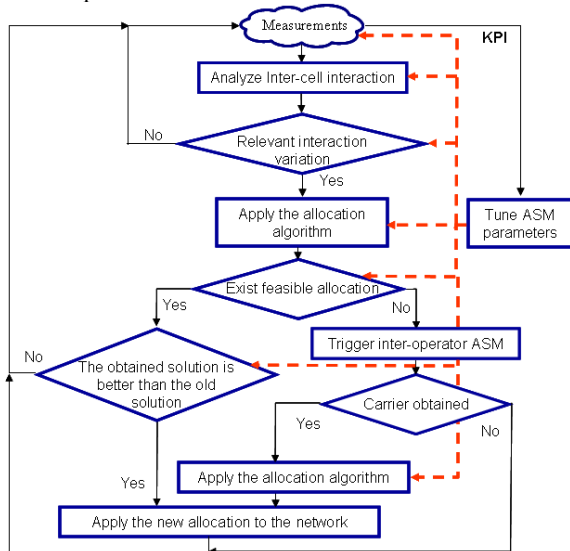

Figure 7 High level vision of an intra-operator ASM algorithm

CONCLUSIONS

This paper has presented a framework where JRRM and ASM mechanisms operate synergistically towards an optimized dynamic spectrum and radio resource usage in heterogeneous wireless networks with multi-operator scenarios. Given the complexity of the problem, the proposed solution follows a layered approach, where both intra and inter-operator levels are considered. Thus, four strategy layers have been identified, together with the time scales at which each of them is applied. The inter-layer operation has also been defined, then illustrating the dynamic operation of the presented framework.

The paper has also emphasized that the solution is sustained on cognitive network features and the intra/inter JRRM/ASM mechanisms have been integrated into the cognitive cycle. Some hints into the different stages of the cognition process have been provided, with particular attention to the decision and act phase, where specific algorithms for each layer have to be considered.

ACKNOWLEDGEMENTS

This work was performed in project E2R-II/E³ which has received research funding from the Community's Sixth/Seventh Framework program. This paper reflects only the authors' views and the Community is not liable for any use that may be made of the information contained therein. The contributions of colleagues from E2R-II/E³ consortium are hereby acknowledged. This work has also been supported by the Spanish Research Council under COGNOS grant (ref. TEC2007-60985).

REFERENCES

- [1] J. A. Hoffmeyer, "Regulatory and Standardization Aspects of DSA Technologies – Global Requirements and Perspectives", First IEEE International Symposium on New Frontiers in Dynamic Spectrum Access Networks (DySPAN 2005), Baltimore, 2005.
- [2] M. Buddhikot, K. Ryan, "Spectrum Management in Coordinated Dynamic Spectrum Access Based Cellular Networks", 1st IEEE international Symposium on New Directions in Dynamic Spectrum Access Networks (DySPAN), Baltimore, MD, November, 2005.
- [3] D. Bourse et al "The E2R II Flexible Spectrum Management (FSM) – Framework and Cognitive Pilot Channel (CPC) Concept – Technical and Business Analysis and Recommendations", E2R II White Paper, November 07
- [4] R. W. Thomas, et al., "Cognitive Networks", First IEEE International Symposium on New Frontiers in Dynamic Spectrum Access Networks (DySPAN 2005), Baltimore, 2005
- [5] E2R2 Project. <http://e2r2.motlabs.com>
- [6] G. Dimitrakopoulos, et al., "Adaptive Resource Management Platform for Future Cooperative Networks, Mobile Networks and Applications Journal, Special issue on Reconfigurable Radio Technologies in Support of Ubiquitous Seamless Computing, Vol. 11, n° 6, December 2006, pp. 799-811
- [7] J. Mitola, *Cognitive Radio: An Integrated Agent Architecture for Software Defined Radio*, PhD Dissertation, KTH, May 2000
- [8] S. Haykin, "Cognitive radio: brain-empowered wireless communications", *IEEE Journal on Selected Areas in Communications*, Vol 23, February 2005
- [9] M. Muck, et al., "Reconfigurable Wireless Communication Systems applying Distributed Decision-Making in a Heterogeneous Radio Environment", 16th IST Mobile and Wireless Communications Summit, Budapest, July 2007.
- [10] J. Nasreddine, O. Sallent, J. Pérez-Romero, R. Agustí, "Novel Inter-Cell Interaction Approach for WCDMA-based Cognitive Networks," IEEE International Conference on Communications (ICC 2007), Glasgow, June 2007
- [11] B. A. Fette, *Cognitive Radio Technology*. Newnes, 2006
- [12] L. Giupponi, R. Agustí, J. Pérez-Romero, O. Sallent, "A Novel Approach for Joint Radio Resource Management Based on Fuzzy Neural Methodology", *accepted for publication in IEEE Transactions on Vehicular Technology*, July, 2007.
- [13] S. Lincke, C. S. Hood, "Load Sharing versus Service Balancing in Integrated Networks", *Journal of Interconnection Networks*, Vol. 6, n° 1, March 2005
- [14] E²R II Deliverable D3.3, "Performance Enhancements Through Reconfigurability Enabled Radio Resource Efficiency Enhancing Schemes", November 2007
- [15] J. Pérez-Romero, O.Sallent, R.Agusti, "A Generalized Framework for Multi-RAT Scenarios Characterisation", *Procs. of the IEEE Vehicular Technology Conference in Spring*, Dublin, Ireland, May, 2007.
- [16] J. Pérez-Romero, O.Sallent, R.Agusti, M.Diaz-Guerra, *Radio Resource Management Strategies in UMTS*, John Wiley & Sons, 2005.
- [17] L. Giupponi, R. Agustí, J. Pérez-Romero, O. Sallent, "Improved Revenue and Radio Resource Usage Through Inter-

operator Joint Radio Resource Management", IEEE International Conference on Communications (ICC 2007), Glasgow, June, 2007.

[18] M. Cave et al., *Essentials of modern spectrum management*, Cambridge University Press, 2007.